



## Standard Practice for Construction of Chain-Link Tennis Court Fence<sup>1</sup>

This standard is issued under the fixed designation F 969; the number immediately following the designation indicates the year of original adoption or, in the case of revision, the year of last revision. A number in parentheses indicates the year of last reappraisal. A superscript epsilon ( $\epsilon$ ) indicates an editorial change since the last revision or reappraisal.

### 1. Scope

1.1 This practice covers fencing around tennis courts, built from various types of chain-link fabric and framework materials, and installation practices for same.

1.2 *This standard does not purport to address all of the safety concerns, if any, associated with its use. It is the responsibility of the user of this standard to establish appropriate safety and health practices and determine the applicability of regulatory limitations prior to use.*

### 2. Referenced Documents

#### 2.1 ASTM Standards:

- A 392 Specification for Zinc-Coated Steel Chain-Link Fence Fabric<sup>2</sup>
- A 491 Specification for Aluminum-Coated Steel Chain-Link Fence Fabric<sup>2</sup>
- A 824 Specification for Metallic-Coated Steel Marcellled Tension Wire for Use with Chain-Link Fence<sup>2</sup>
- F 552 Definitions of Terms Relating to Chain Link Fencing<sup>2</sup>
- F 567 Practice for Installation of Chain-Link Fence<sup>2</sup>
- F 626 Specification for Fence Fittings<sup>2</sup>
- F 668 Specification for Poly (Vinyl Chloride) (PVC)-Coated Steel Chain-Link Fence Fabric<sup>2</sup>
- F 900 Specification for Industrial and Commercial Swing Gates<sup>2</sup>
- F 934 Specification for Standard Colors for Polymer-Coated Chain Link Fence Materials<sup>2</sup>
- F 1043 Specification for Strength and Protective Coatings on Metal Industrial Chain Link Framework<sup>2</sup>
- F 1083 Specification for Pipe, Steel, Hot-Dipped Zinc Coated (Galvanized) Welded for Fence Structures<sup>2</sup>
- F 1345 Specification for Zinc-5% Aluminum-Mischmetal Alloy-Coated Steel Chain-Link Fence Fabric<sup>2</sup>
- F 1664 Specification for Poly (Vinyl Chloride) (PVC) Coated Steel Tension Wire Used with Chain-Link Fence<sup>2</sup>

### 3. Terminology

3.1 Definitions—See Definitions F 552 for definitions of terms used in this practice.

<sup>1</sup> This practice is under the jurisdiction of ASTM Committee F-14 on Fences and is the direct responsibility of Subcommittee F14.10 on Specific Applications.

Current edition approved November 10, 1996. Published December 1997. Originally published as F 969 – 86. Last previous edition F 969 – 92.

<sup>2</sup> Annual Book of ASTM Standards, Vol 01.06.

### 4. Summary of Practice

4.1 This practice is intended primarily to guide those responsible for or concerned with the design and installation of chain-link fencing around tennis courts.

4.2 This practice does not intend to preclude any practice that has proven equal to or given better performance under varying conditions such as location, weather, intended use, etc.

### 5. Significance and Use

5.1 The intended use of this practice is for 10- or 12-ft high chain-link fencing as complete enclosures around single or multiple tennis courts, or as backstops at either end of tennis courts.

5.2 This practice is not intended for applications where fencing higher than 12 ft is desired for a special application.

5.3 *Caution Regarding Windscreens*—If wind screens are to be installed at the time of fence erection or at a later time, it is advisable to use stronger framework and parts and closer spacing of posts or back bracing depending upon the type of screening material to be used, area of fence to be covered, and local wind conditions.

### 6. Classification

6.1 The four types of chain-link fencing described in this practice are classified as follows:

6.1.1 *Type I*—Built with aluminum-coated steel chain-link fence fabric as specified in Specification A 491.

6.1.2 *Type II*—Built with zinc-coated steel chain-link fence fabric as specified in Specification A 392, Class 1 coating only.

6.1.3 *Type III*—Built with zinc-5% aluminum-mischmetal alloy-coated steel chain-link fence fabric as specified in Specification F 1345, in a choice of Class 1 or Class 2 coating, as selected.

6.1.4 *Type IV*—Built with poly(vinyl chloride) (PVC)-coated steel chain-link fence fabric as specified in Specification F 668, in a choice of Class 1, Class 2a, or Class 2b coating, as selected.

### 7. Ordering Information

7.1 Purchase orders, construction specifications, or detailed drawings should include the following information:

7.1.1 Quantity or total measurements in lineal feet of fence and gates.

7.1.2 Type of fence (Type I, II, III or IV) (see 6.1).

7.1.3 Class of fence if Type III (Class 1 or 2) (see 6.1.3).

7.1.4 Class of fence if Type IV (Class 1, 2a, or 2b) (see 6.1.4) and color (see 8.1.2)

7.1.5 If framework, fittings and gates are to be color coated, select color from Specification F 934.

7.1.6 Height of fence (10 or 12 ft).

7.1.7 Number of horizontal rails and location.

7.1.8 Bottom tension wire, if specified.

7.1.9 Depth and diameter of concrete post footings, if other than as indicated in Practice F 567.

7.1.10 Spacing of line posts, if other than as indicated in Practice F 567.

7.1.11 Any details peculiar to the project, such as special finishing of tops of concrete post footings, setting of posts in concrete curbs, etc. (see 9.2.2 and 9.2.3).

NOTE 1—A typical ordering description is as follows: 360 lineal ft chain-link tennis court fence to make a full enclosure 60 by 120 ft with 3 ft gate at one corner, Type I, 12 ft high, 3 horizontal rails (top, middle, and bottom), furnished and erected as shown on the enclosed drawing, and in accordance with ASTM F 969.

7.2 A detailed drawing or drawings showing the complete layout of the fence line, together with typical elevations, details of pavement around post footings, etc., should be a part of the purchase order or construction contract.

**8. Materials**

**8.1 Chain-Link Fabric:**

8.1.1 If Type III is selected, indicate whether Class 1 or 2 is desired.

8.1.2 If Type IV is selected, indicate whether Class 1, 2a, or 2b is desired, and select color of fabric coating in accordance with Specification F 934.

8.1.3 Size of wire shall be 0.120 in. (11 gage). If Type IV is selected, this shall be the size of the metallic-coated core wire.

8.1.4 Size of fabric mesh shall be 1 3/4 in.

8.1.5 Height of fabric shall be 10 or 12 ft, as selected.

8.1.6 Fabric selvage shall be knuckled top and bottom.

**8.2 Posts:**

8.2.1 Posts shall be as selected from Specifications F 1043 and F 1083.

8.2.2 The posts shall not be splice-welded.

**8.3 Horizontal Rails:**

8.3.1 Horizontal rails shall be as selected from Specifications F 1043 and F 1083.

8.3.2 All fences shall have a top rail. Fences 12 ft in height shall have a continuous middle rail. Additional rails at mid-points or at the bottom of the fence may be specified.

**8.4 Bottom Tension Wire:**

8.4.1 Bottom tension wire shall be used except where continuous bottom rail is specified.

8.4.2 Bottom tension wire shall be in accordance with Specification A 824 for metallic coated chain link fabric and Specification F 1664 for PVC coated chain link fabric.

**8.5 Fittings:**

8.5.1 All fittings shall conform to Specification F 626. If Type IV fabric is selected and PVC-coated posts and rails are also selected, all fittings shall be polymer coated as specified in Specification F 626, Section 11.

**8.6 Gates:**

8.6.1 All gates shall be fabricated in accordance with Specification F 900.

8.6.2 Minimum width of gate opening shall be 3 ft.

8.6.3 All single walk gates shall be 7 ft high with a transom panel above the gate extending to full height of the fence.

8.6.4 Gates shall have hinges to provide a full 180° swing from the closed to the open position.

8.6.5 Gate latch shall have provision for secure locking with a padlock.

8.6.6 Gate latch shall have a built-in provision to permit the gate to open outward only.

**9. Installation**

9.1 Lay out the fence lines as shown in Fig. 1, Fig. 2, or Fig. 3.

9.2 Installation shall be in accordance with Practice F 567 with the following additional provisions or exceptions:

9.2.1 Unless otherwise specified, the chain-link fabric shall be placed on the playing side of the fence enclosure or backstops.

9.2.2 If fence is installed in concrete curbs around the perimeter of the tennis court(s), provide sleeves in the curbs for this purpose, then set the posts as indicated in Practice F 567.

9.2.3 Since in most cases it is impractical to pave the courts after setting the posts, it becomes necessary to cut through the

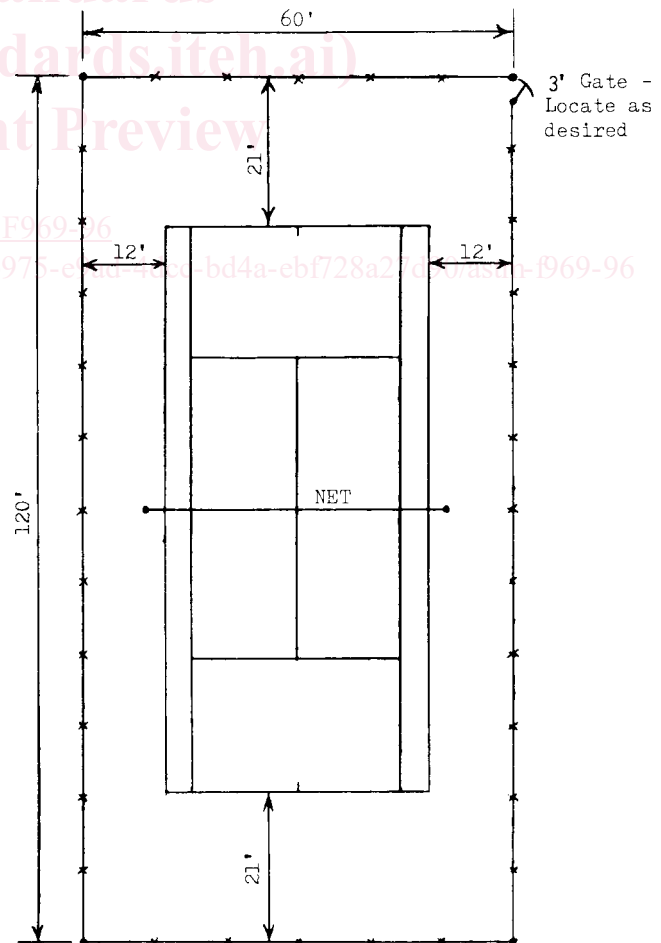

FIG. 1 Typical Fence Layout for Complete Enclosure of One Standard 36 by 78 Ft Doubles Court